

Reliability in Action

L936H Wheel Loader

Gross Power: 132HP@2150rpm

Operating Weight: 10786KG

Payload: 3000KG

CEV-IV Certified

Higher fuel efficiency.
More productivity.



Technical Specifications

Standard Equipment

Engine	
Make	WEICHAI
Model	WP4.6NG135E502
Type	Electronically controlled CRDI engine
Gross Power hp@2150rpm	132
Maximum Torque Nm@1400rpm	630
Engine exhaust after treatment	DOC + SCR + ASC
Working Modes	3

Transmission	
Make	SDLG
Model	TP170 - 5 Ton capacity Transmission
Torque Converter	Single phase, 4 elements, twin turbine, hydraulic converter
Travel Speed km/hr	Forward Reverse
1 st gear	0~13 0~17
2 nd gear	0~38

Axles	
Make	SDLG make with Dry Disc brakes
Front	AL20 Series Heavy Duty axles with 20T carrying capacity
Rear	AL20 Series Heavy Duty axles with 20T carrying capacity

Hydraulic system	
Loader Hydraulic operation	Pilot operated with single Joy Stick
Pilot System working pressure	3.5MPa
Loader Arm Linkage	Z Bar
Main Pump Type	Gear Pump
Maximum Flow ltrs/min	220L/min
System working pressure Mpa	17.5

Hydraulic Cycle Time Sec	
Lifting Time (fully loaded)	5.3
Lowering Time (empty)	2.9
Dumping Time (Empty)	1
Total	9.2

Steering System	
Type	Gear pump Full hydraulic load sensing, articulated steering
Working pressure Mpa	12
Maximum Flow ltrs/min	287

Service & Maintenance	
Airfilter	Dual Air Filters with Turbo Precleaner
Fuel Filters	2
Water Seperator	1 with electrical priming motor
Hydraulic Filter	1
Transmission filter	1

Optional Attachments	
HD Bucket m ³	1.5
LM Bucket m ³	3
Side Dump Bucket m ³	1.4
Precleaner	Oil bath Precleaner

Brake System	
Service brake	Air over Hydraulic Disc Brakes with single brake pedal
Parking brake	Electronically controlled Pneumatic internal expanding drum type

Tyres	
Front	Size 17.5X25 L3
Rear	17.5X25 L3

System refill Capacity & Interval (L)	Tank Capacity	Refill Interval
Fuel	200	
Adblue	16	
Engine coolant	25	2000 Hrs
Engine oil	18	250 Hrs
Transmission oil	44	1000 Hrs first 50 hrs
Axle & Final drive oil front	18	1000 Hrs first 50 hrs
Axle & Final drive oil rear	20.5	1000 Hrs first 50 hrs
Hydraulic oil volume in tank	128	2000 Hrs
Brake System	4	

Electrical System	
Voltage	24V
Batteries	2

Cabin	
AC Cabin	Standard
AC	Standard with dual filters
Operator Seat	Mechanical Suspension Seat
Music System	MP3 Player with Bluetooth mobile connection
Seat Belt	Standard

Payload			
Payload Capacity kg	3000	3000	3000
Bucket Volume Heaped ISO/SAE cu.m (HD, GP, LM)	1.5	1.8	3
Volume at 110% Fill Factor m ³	1.65	1.98	3.3
Operating Weight kg	10729	10500	10786
Breakout Force kN	114	96	82
Static Tipping Load Straight	7370	7600	7105
Static Tipping Load Full Turn	6370	6600	6105
Maximum Tractive Force kN	100	100	100

Dimensions

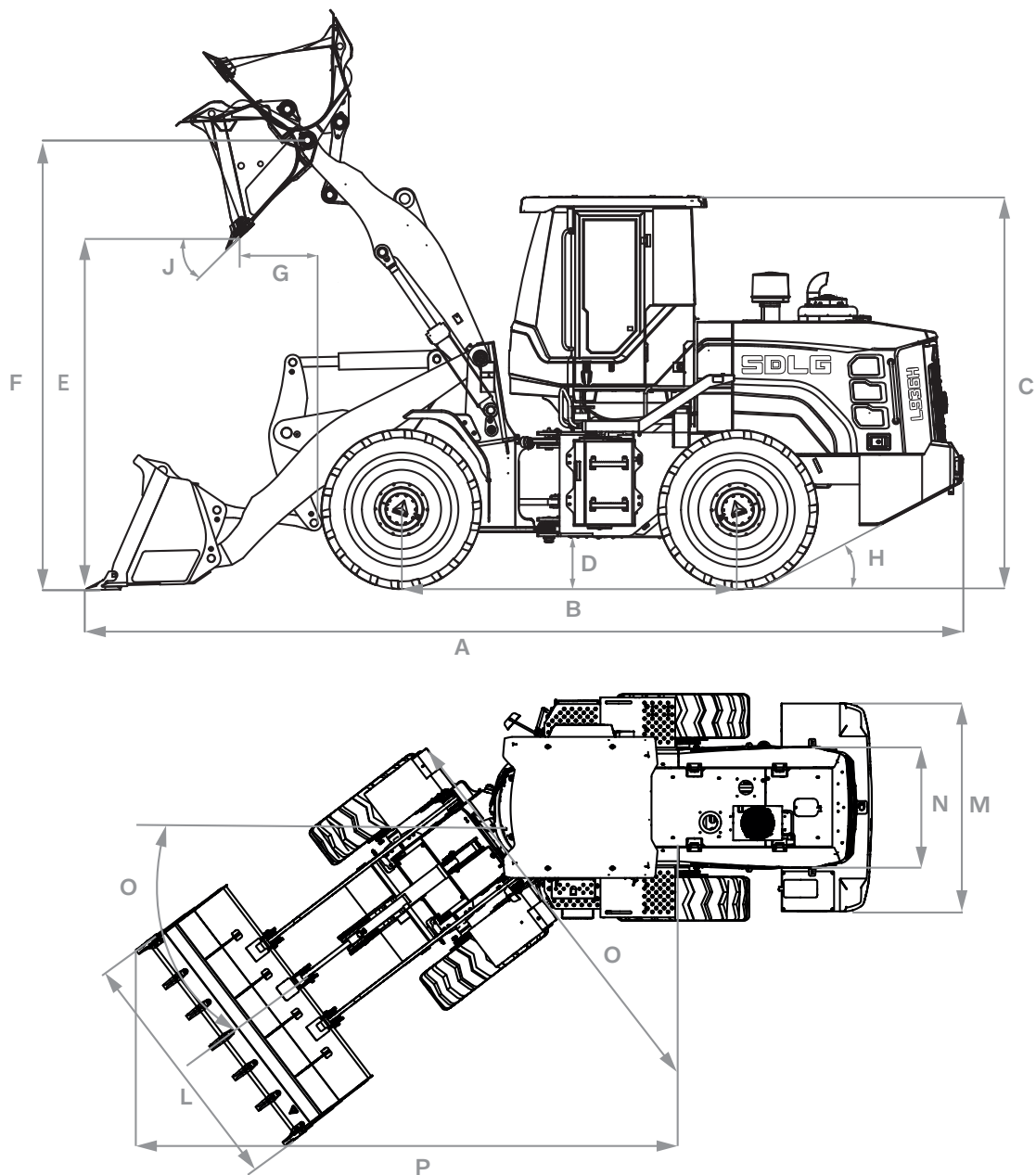

Loader Dimension (Bucket Size)	1.5	1.8	3
Length A	7220	7240	7150
Width L	2510	2520	2915
Height C	3170	3170	3170
Wheel Base B	2850	2850	2850
Minimum Ground clearance D	370	370	370
Maximum Dump Height E	3005	2950	2790
Maximum Hinge Pin Height F	3790	3790	3790
Maximum Reach G	1005	1050	1215
Dumping Angle J	-45°	-45°	-45°
Bucket roll back at ground level K	45°	45°	45°
Width outside of rear wheel M		2310	
Steering angle		37°	
Minimum turning radius outside rear wheels (mm) O		5250	
Horizontal crossing radius outside bucket (mm) P		6065	
Gradeability H		30°	
Wheel Tread N		1865	

SDLG Dealer Network

India

Advanced Construction Technologies Pvt. Ltd.

Tamil Nadu, Union Territories of Andaman
Nicobar Islands, Pondicherry and Lakshadweep
Dealer Partner: Mr. Siddharth Raman
Ph: +91 98847 57350
Email: siddharth.raman@actind.com

Alpha Teknisk Pvt. Ltd.

Delhi-NCR, Haryana, Uttarakhand
Dealer Partner: Mr. Manoj Kotru
Ph: +91 98110 23172
Email: m.kotru@alphatechnical.in

Alpha Teknisk Pvt. Ltd.

Uttar Pradesh
Dealer Partner: Mr. Sarthak Kotru
Ph: +91 98733 25118
Email: sarthak@alphatechnical.in

BSES India Pvt. Ltd.

Southern Rajasthan
Dealer Partner: Mr. Kedar Singh Rathore
Ph: +91 98290 41246
Email: ksathore@bsesindia.com

DRS Earthwork Pvt. Ltd.

Northern Maharashtra
Dealer Partners: Mr. Divish Sabhlok
Ph: +91 98997 93431
Email: divish.sabhlok@drsgroupindia.com

Encore Heavy Machinery Pvt. Ltd.

Karnataka
Dealer Partner: Mr. Vinayak Nayak
Ph: +91 80 29734009, +91 78999 03813
Email: vinayak@encorece.in

ESDEE Solutech

Northern Rajasthan
Dealer Partner: Mr. O P Dawar
Ph: +91 96360 76000
Email: op.dawar@esdeesolutech.net

Infra Equip Pvt. Ltd

Jharkhand
Dealer Partner: Mr. Dinesh Pandey
Mr. Naren Pandey
Ph: +91 94711 91178, +91 62068 03435,
+91 97714 72300, +91 70701 92510
Email: dineshpandey@infraequip.com
npandey@infraequip.com

Navin Infrasolutions Pvt. Ltd.

Madhya Pradesh
Dealer Partners: Mr. Navin Bhandari
Ms. Seema Bhandari
Mr. Nilesh Bhandari
Ph: +91 93000 77300, +91 93025 55002,
+91 930247 7346, +91 93000 77308
Email: navinbhandari@navininfra.com
seemabhandari@navininfra.com
nileshbhandari@navininfra.com

PACT Machines Pvt. Ltd.

Kerala
Dealer Partner: Mr. Siddharth Raman
Ph: +91 99959 22350
Email: siddharth.raman@actind.com

PAL Infrastructure Solutions

Jammu & Kashmir, Himachal Pradesh,
Punjab and Chandigarh
Dealer Partner: Mr. Nishant Luthra
Ph: +91 98110 42580
Email: nishantluthra@luthragroup.net

Pollutech Engineering

Orissa
Dealer Partner: Mr. Dilip Tripathy
Ph: +91 95830 72667, +91 77350 65864
Email: dilip@pollutech.in

Ramanand Power Systems Pvt. Ltd.

Telangana and Andhra Pradesh
Dealer Partner: Mr. Rama Rao
Mr. Anand
Mr. Nagarjuna Madava
Ph: +91 98451 50173, 94920 54224
+91 99909 75051
Email: sreeram@ramanand.co.in
anand@ramanand.co.in
nagarjuna@ramanand.co.in

Suchita Millennium Projects Pvt. Ltd.

West Bengal, Sikkim and Bihar
Dealer Partner: Mr. Raghupati Bhuwarka
Ph: +91 33 2219 7951, 7952/ 3183
Email: raghupatibhuwarka@suchitagroup.com

Suchita Earth Moving Solutions

Assam, Tripura, Meghalaya, Nagaland, Mizoram,
Arunachal Pradesh and Manipur
Dealer Partner: Ms. Amita Bhuwarka
Ph: +91 99540 89208
Email: amitabhhuwarka@suchitagroup.com

SVP Mining Technologies Pvt. Ltd.

Northern Maharashtra
Dealer Partner: Mr. Pramood Patwardhan
Ph: +91 84350 05500
Email: pramod@svpgroup.net

Team Engineers

Southern Maharashtra and Goa
Dealer Partners: Mr. Ajit Bafna
Mr. Shridhar Bhat
Mr. Anand Rajore
Ph: +91 93701 45680, +91 93701 45660,
+91 98220 33202
Email: ajit@teamengineers.co.in
srb@teamengineers.co.in /
anand.rajore@teameng.co.in

West India Equipments Pvt. Ltd.

Gujarat, Dadra & Nagar Haveli and
Daman & Diu
Dealer Partner: Mr. Jesal Vora
Ph: +91 98256 09097, +91 98795 35995
Email: jesal@westindiaequip.com

International

Solution Engineering Ltd.

Bangladesh
Dealer Partner:
Mr. Rashed Chowdhury
Ph: +880 18193 12618
Email:
rashed.chowdhury@sel-pti.com.bd

Riwang Heavy Equipment and Services



Bhutan
Dealer Partner:
Mr. Rinzy Wangchuk
Ph: +97 517111965
Email: rinzy@riwang.com

Dax Engineering Co. (Pvt) Ltd.

Sri Lanka
Dealer Partner:
Mr. Wijayasinghe SS
Ph: +94 714273900 /
+94 714273920
Email: wije@daxholdings.lk

Explore Earth Movers Pvt. Ltd.

Nepal
Dealer Partner:
Mr. Sushil Shrestha
Ph: +977 985 1107251
Email: sushil@exploreintl.com

Connect with us on:  
Whatsapp:  +91 72590 13677

Toll Free: 1800-108-6856
www.sdlgindia.com

Member of The Volvo Group

